

TLS-Z GD2

Description

The TLS-ZR GD2 and TLS-ZL GD2 are additions to the existing TLS GD2 range of guard locking switches. The TLS-ZR GD2 is a power-to-release and the TLS-ZL GD2 is a power-to-lock unit. They may be used as part of a guard locking system to achieve performance Level "e" to EN/ISO 13849-1. They are certified by the TÜV as meeting EN/ISO 13849-1. In mechanical configuration they are identical to the existing TLS-GD2 range with the exception that they include an additional RFID door target which is mounted close coupled with the supplied fully-flexible actuator.



These switches have built in microprocessor technology and have two channel OSSD solid-state outputs. Locking/unlocking is achieved using a logic level signal input. The RFID door target is uniquely coded and provides the internal microprocessor with additional door position information. Therefore, in the event of a broken or missing actuator key the microprocessor will shut down the OSSD safety outputs. This extra functionality enables performance level "e" to EN/ISO 13849-1 to be reached as there is no reliance on fault exclusion for a broken or missing actuator key.

The TLS-GD2 range are positive mode, tongue operated, guard locking interlock switches that can lock a machine guard closed until power is isolated and ensure that it remains isolated while the guard is open. The TLS-ZR GD2 and TLS-ZL GD2 head has two entry slots and it can be rotated to provide three actuator entry points. A blanking plug is provided to seal the unused slot. The TLS-ZR GD2 is a power-to-release switch, the guard may only be opened when a logic signal is applied to the switch after which the internal microprocessor will enable the internal solenoid, which releases the lock mechanism. The TLS-ZL GD2 is a power-to-lock switch, the guard will be locked when a logic signal is applied to the switch after which the internal microprocessor will enable the internal solenoid, which engages the lock mechanism.

Two manual release points with security screws allow the locked switches to be released in emergencies. An optional lid-mounted key-release style can also be supplied. Each switch has semiconductor OSSD safety outputs that may be connected in series with other safety components that also have OSSD solid-state outputs (for example, the SensaGuard range of non-contact switches). A stainless-steel actuator guide is fitted to protect the unit from actuator damage due to poor guard alignment or guard wear. TLS-Z GD2 has an ingress protection rating of IP69K making them suitable for harsh washdown applications as found in the food and beverage, pharmaceutical, solar, and semiconductor industries.

IMPORTANT

With the TLS-ZL GD2 power-to-lock style, provisions may be required to ensure that a dangerous situation can not result from open circuit faults or power failures.

Features

- Meets PLe to EN/ISO 13849-1
- Solid-state OSSD outputs series connectable to ISO 14119
- RFID uniquely coded door target
- Easy QD connection
- Same mechanical arrangement as standard TLS-GD2
- High locking force ≤ 2000 N (450 lb)

Specifications

Safety Ratings	
Standards	IEC 60947-5-3, IEC 60947-5-1, IEC 61508, EN ISO 13849-1, IEC 62061, ISO 14119
Safety Classification	PLe per ISO 13849-1, SIL 3 per IEC 61508 and IEC 62061, PDF-M per IEC 60947-5-3
Functional Safety Data (related to Safety Contacts) * Note: For up-to-date information, visit http://www.ab.com/Safety/	PFH _D : 1.69 x10 ⁻⁹ Dual channel interlock may be suitable for use in application up to PLe (according to ISO 13849-1) and for use up to SIL3 systems (according to IEC 62061) depending on application characteristics. Mission time/PTI: 20 years or 1 x 10 ⁶ cycles.
Certifications	CE Marked for all applicable EU directives, cULus (UL 508), and TÜV.
Outputs (Guard Door Closed & Locked)	
Safety Outputs	2 x PNP, 0.2 A max., Status: ON (+24V DC)
Auxiliary Outputs	1 x PNP, 0.2 A max., Status: OFF (0V DC)
Operating Characteristics	
TLSZR-GD2	Power to release
TLSZL-GD2	Power to lock
Assured Locking Distance [mm (in.)]	Max. door target distance: 13 (0.51), max. clearance between actuator base and switch in door-closed position: 5 mm
Torque for M5 Mounting	1.4 N•m (12.39 lb•in)
Torque for Cover Mounting	1.2 N•m (10.62 lb•in)
Locking Force F _{max} (EN/ISO 14119)	Plastic pins: 1950 N (488 lb), Steel bolts: 2600 N (585 lb)
Locking Force F _{zn} (EN/ISO 14119)	Plastic pins: 1500 N (337 lb), Steel bolts: 2000 N (450 lb)
Output Current, Max. (all outputs)	200 mA
Current Consumption	50 mA – Solenoid not energized (no load supply current); 120 mA (260 mA inrush) – Solenoid energized (no load supply current); <0.5 mA DC – Off state
Solenoid Duty Cycle	100%
Maximum Number of Switches, connected in series	Unlimited
Operating Voltage U _e	24V DC +10%/-15% Class 2
Operating Frequency	1 Hz
Actuation Speed, Max.	160 mm (6.29 in.) per second
Actuation Speed, Min.	100 mm (3.94 in.) per minute
Response Time	75 ms 1st switch, 25 ms each additional switch (Off)
Utilization Category	DC-13 24V 200 mA (IEC 60947-5-2)
Rated Impulse withstand Voltage	250V
Pollution Degree	3
Protection Type	2
Mechanical Life	1,000,000 operations
Actuation Speed, Max.	160 mm (6.29 in.) per second
Operating Radius (only for use with flexible actuator)	80 mm (3.15 in.)
Environmental	
Enclosure Type Rating	NEMA 3, 4X, 12, 13; IP66, IP69K
Operating Temperature [C (F)]	-10...+60 ° (14...140 °)
Relative Humidity	5...95%
Shock	IEC 68-2-27 30 g 11 ms
Vibration	IEC 68-2-6 10-55 Hz
Frequency	IEC 61000-4-3, IEC 61000-4-6
Physical Characteristics	
Housing Material	UL approved glass-filled PBT
Actuator Material	Stainless steel
Target Type	UL approved glass-filled PBT
Weight [g (lb)]	400 (0.88)
Color	Red





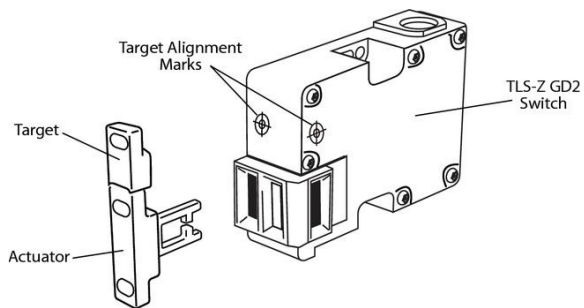



* Usable for ISO 13849-1:2006 and IEC 62061. Data other than B10d is based on:- Usage rate of 1op/10 min., 24 hrs/day, 360 days/year, representing 51840 operations per year- Mission time/Proof test interval of 30 years

Product Selection



Description	Cat. No.
TLS-ZR GD2 guard locking switch OSSD outputs power-to-release QD 24V	440G-TZS21UPRH
TLS-ZL GD2 guard locking switch OSSD outputs power-to-lock QD 24V	440G-TZS21UPLH

Accessories

Description	Cat. No.
 Spare RFID Door Target	440G-ATZA
 Fully flexible actuator	440G-A27143
 Cover for TLS-1 with external override key for series E and later	440G-A27371
 Cover for TLS-1 with override key attached for series E and later	440G-A27373
 Emergency override key	440G-A36026
 Flexible release—1 m (3.28 ft) cable	440G-A27356
 Flexible release—3 m (9.84 ft) cable	440G-A27357
 Dust cover	440K-A17183

Approximate Dimensions

Dimensions are shown in mm (in.). Dimensions are not intended to be used for installation purposes.

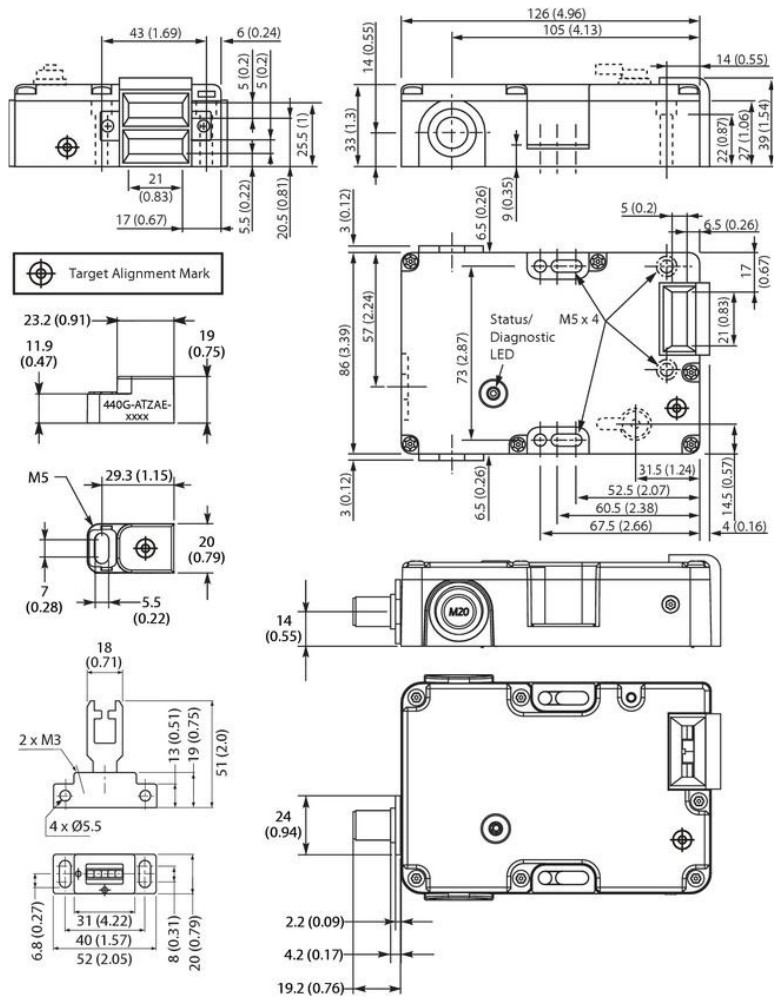

Typical Wiring Diagrams

Description	Color	Function	No. of Pins
8-pin micro (M12)			
8-pin cordset 889D-F8AB- \star or cable version	White	Aux	1
	Brown	24V DC+	2
	Green	Lock	3
	Yellow	Safety B+	4
	Grey	Safety A	5
	Pink	Safety B	6
	Blue	Gnd/0V	7
	Red	Safety A+	8

\star Replace the symbol with 2 (2 m), 5 (5 m) or 10 (10 m) for standard cable lengths.